

# RWM'S NEW

## Light Duty Inverted Cargo Caster

*Ideal for Air Cargo and Conveyor Applications*

- **Economical**
- **TRUE 300 pound capacity**
- Hardened raceways
- Thread guards
- Ball bearings
- Equipped with phenolic wheel

### PHENOLIC WHEEL OFFERS:

- High impact resistance
- Ease of rollability
- Cost effective
- Resistant to moisture and chemicals

### APPLICATIONS:

- Airline/aerospace industry
- Light duty cargo handling
- Textile industry
- Conveyor applications
- Freight handling

#### RWM CASTERS

1225 Isley Road • Gastonia, NC 28052  
Phone: 800-634-7704 • Fax: 800-253-6634  
www.rwmcasters.com

*Quality products on time. RWM Casters. The value added supplier.*

Easy To Order  
with our

**RAPIDSTOCK™**  
PROGRAM

Large inventory of our  
most popular products

Ready to ship in  
1 to 5 days

Order by phone, fax  
or internet



26-DUB-0312-S-TG-LD

Light Duty Inverted Cargo Caster



**RWM'S NEW**

# Light Duty Inverted Cargo Caster

*Economical Caster Equipped with Phenolic Wheel*



26-DUB-0312-S-TG-LD

**Easy To Order**

with our









**RAPIDSTOCK**  
PROGRAM

Large inventory of our most popular products

Ready to ship in 1 to 5 days

Order by phone, fax or internet

**Light Duty Inverted Cargo Caster**

 Model Number	DBL	 Axle Diameter	 Diameter	 Wheel Width	 Wheel Bearing	 Wheel Type	 Capacity	 Overall Height	 Swivel Lead
26-DUB-0312-S-TG-LD	1-5/8"	5/16"	3"	1-1/4"	Ball Bearing	Phenolic	300 lbs.	4"	1"

## Standard Top Plate

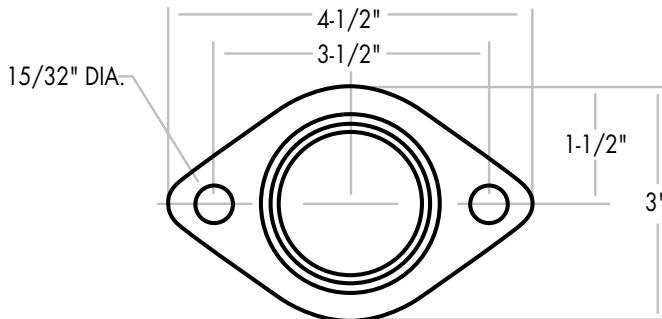

**RWM CASTERS**

1225 Isley Road • Gastonia, NC 28052  
 Phone: 800-634-7704 • Fax: 800-253-6634  
 www.rwmcasters.com  
 Quality products on time. RWM Casters. The value added supplier.

